



Micro Systems Technologies
engineering for life

LiS 2650

LITRONIK
Lithium Iodine
High Energy Battery

KEY FEATURES

- For implantable pulse generators or other medical devices with highest demand in reliability
- Highest volumetric energy densities
- Lowest self-discharge rates
- Solid-state battery
- Long operational safety



LiS 2650

Lithium Iodine High Energy Battery



Download PDF

Technical Data

Chemistry	Li-Iodine
Construction	Single anode design
Rated capacity (at 100 kΩ)	1.21 Ah
Energy density	1232 mWh/cm ³
Nominal voltage	2.8 V
Cut-off voltage	1.8 V
Self-discharge (at 37°C)	< 7% within 10 years
Mass	11.8 g
Volume	2.7 cm ³
Case material	1,4306 (X2 CrNi 19.11) hermetically sealed
Case polarity	Positive
Typical application	Implantable pulse generators

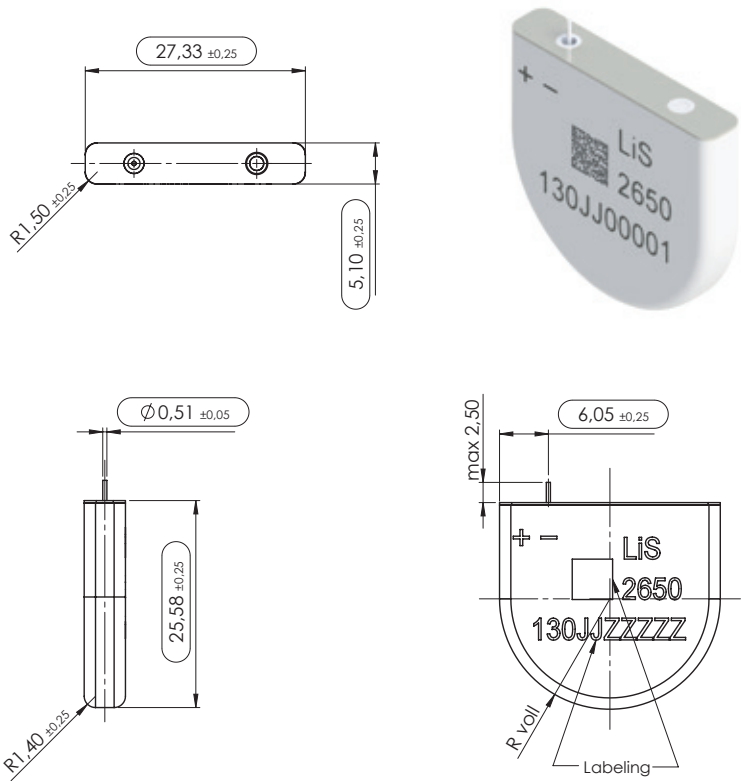

Options

Custom pin configuration	available
Application specific testing	available
Custom labeling	available
Custom packaging	available

LiS 2650 / Discharge at 100 kOhm (without self discharge)

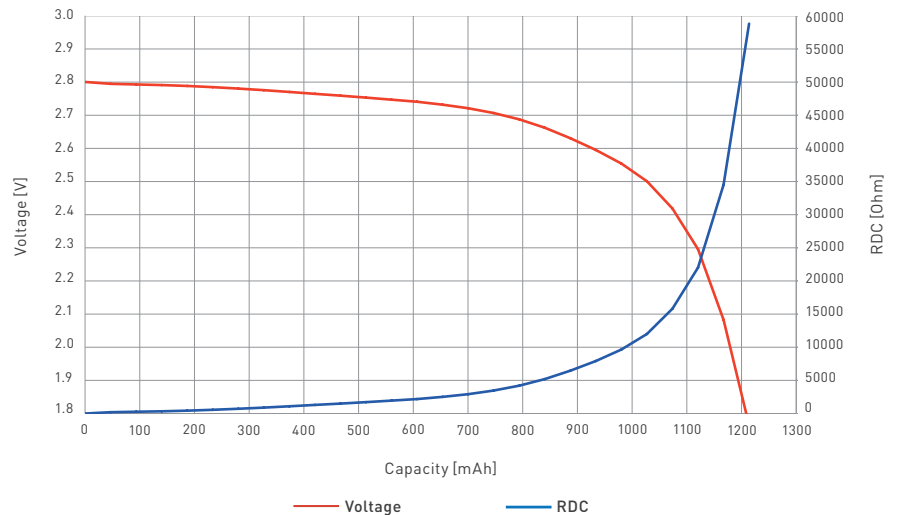

LITRONIK power sources provide today's state-of-the-art in battery technology for implantable medical devices. The batteries are manufactured within a tightly controlled atmosphere to ensure highly re-producible electrical characteristics. A completely laser welded titanium case and a high-precision metal-to-glass feedthrough guarantee hermeticity and safe operation. LITRONIK's quality system derives from the requirements of life sustaining implants and assures 100% traceability of processes and materials.



MST Showroom

LITRONIK
an MST company

LITRONIK Batterietechnologie GmbH
Birkwitzer Straße 79
DE-01796 Pirna, Germany
Phone +49 (3501) 5305-0
info.litronik@mst.com
www.mst.com

MST
Micro Systems Technologies
engineering for life

Micro Systems Technologies Management GmbH
Sieversufer 7-9
DE-12359 Berlin, Germany
Phone +49 (30) 68905-4001
info@mst.com
www.mst.com